

1. Features

- **Medium-voltage and Standard-voltage Operation**
 - 2.5 (V_{CC} = 2.5V to 5.5V)
- **User-selectable Internal Organization**
 - 1K: 128 x 8 or 64 x 16
- **Three-wire Serial Interface**
- **2 MHz Clock Rate (5V)**
- **Self-timed Write Cycle (10 ms max)**
- **High Reliability**
 - **Endurance: 1 Million Write Cycles**
 - **Data Retention: 100 Years**
- **8-lead TSSOP and 8-lead JEDEC SOIC Packages**

2. Description

The AT93C46D provides 1024 bits of serial electrically erasable programmable read only memory (EEPROM) organized as 64 words of 16 bits each, when the ORG pin is connected to VCC and 128 words of 8 bits each when it is tied to ground. The device is optimized for use in many automotive applications where low power and low voltage operations are essential. The AT93C46D is available in space-saving 8-lead TSSOP and 8-lead JEDEC SOIC packages. The AT93C46D is enabled through the Chip Select pin (CS), and accessed via a 3-wire serial interface consisting of Data Input (DI), Data Output (DO), and Shift Clock (SK). Upon receiving a Read instruction at DI, the address is decoded and the data is clocked out serially on the data output pin DO. The WRITE cycle is completely self-timed and no separate erase cycle is required before write. The Write cycle is only enabled when it is in the Erase/Write Enable state. When CS is brought “high” following the initiation of a write cycle, the DO pin outputs the Ready/Busy status.

Table 2-1. Pin Configuration

Pin Name	Function
CS	Chip Select
SK	Serial Data Clock
DI	Serial Data Input
DO	Serial Data Output
GND	Ground
VCC	Power Supply
ORG	Internal Organization

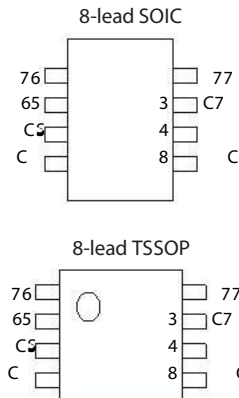

Three-wire Automotive Temperature Serial EEPROMs

1K (128 x 8 or 64 x 16)

AT93C46D



3. Absolute Maximum Ratings*

Operating Temperature.....	□ 55°C to +125°C
Storage Temperature.....	□ 65°C to +150°C
Voltage on Any Pin with Respect to Ground	□ 1.0V to +7.0V
Maximum Operating Voltage	6.25V
DC Output Current.....	5.0 mA

***NOTICE:** Stresses beyond those listed under “Absolute Maximum Ratings” may cause permanent damage to the device. This is a stress rating only and functional operation of the device at these or any other conditions beyond those indicated in the operational sections of this specification is not implied. Exposure to absolute maximum rating conditions for extended periods may affect device reliability

Figure 3-1. Block Diagram

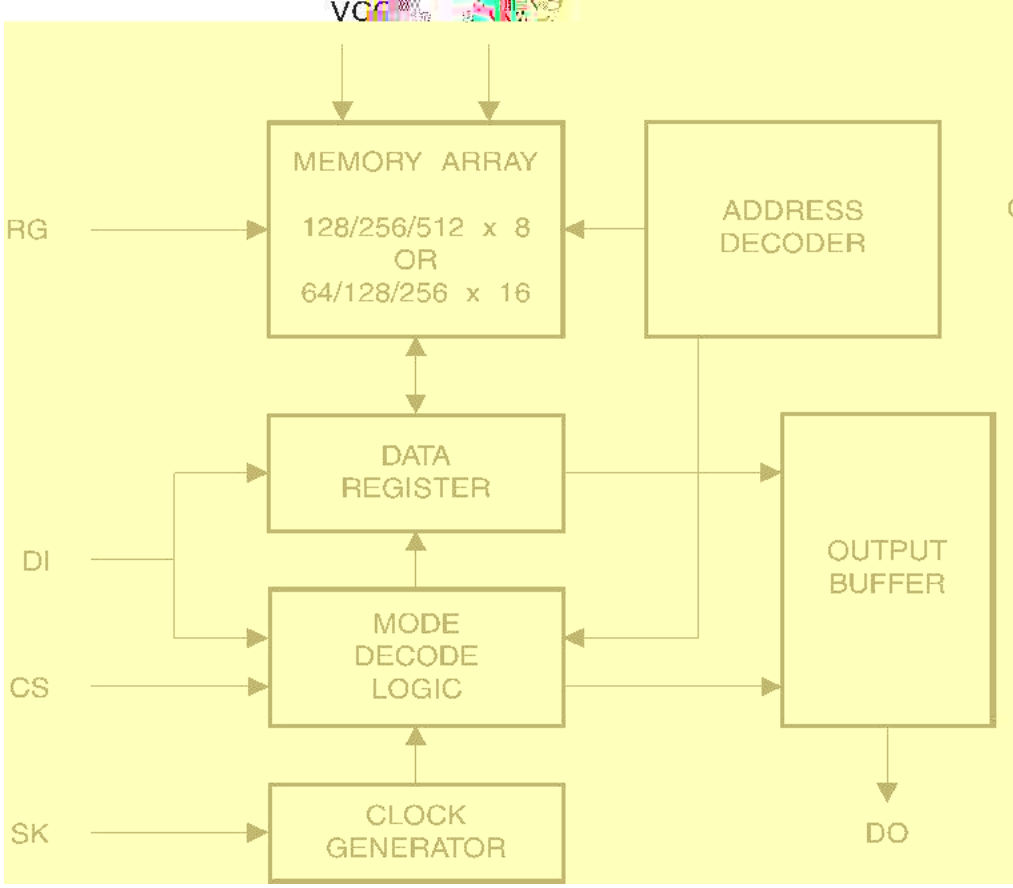

Note: When the ORG pin is connected to VCC, the “x 16” organization is selected. When it is connected to ground, the “x 8” organization is selected.

Table 3-1. Pin Capacitance⁽¹⁾

Applicable over recommended operating range from $T_A = 25^\circ\text{C}$, $f = 1.0\text{ MHz}$, $V_{CC} = +5.0\text{V}$ (unless otherwise noted)

Symbol	Test Conditions	Max	Units	Conditions
C _{OUT}	Output Capacitance (DO)	5	pF	V _{OUT} = 0V
C _{IN}	Input Capacitance (CS, SK, DI)	5	pF	V _{IN} = 0V

Note: 1. This parameter is characterized and is not 100% tested.

Table 3-2. DC Characteristics

Applicable over recommended operating range from: $T_A = -40^\circ\text{C}$ to $+125^\circ\text{C}$, $V_{CC} = +2.5\text{V}$ to $+5.5\text{V}$ (unless otherwise noted)

Symbol	Parameter	Test Condition	Min	Typ	Max	Unit
V _{CC1}	Supply Voltage		2.5		5.5	V
V _{CC2}	Supply voltage		4.5		5.5	V
I _{CC}	Supply Current	V _{CC} = 5.0V		0.5	2.0	mA
				0.5	2.0	mA
I _{SB1}	Standby Current	V _{CC} = 2.5V		6.0	10.0	μA
I _{SB2}	Standby Current	V _{CC} = 5.0V		10.0	15.0	μA
I _{IL}	Input Leakage	V _{IN} = 0V to V _{CC}		0.1	1.0	μA
I _{OL}	Output Leakage	V _{IN} = 0V to V _{CC}		0.1	1.0	μA
V _{IL(1)}	Input Low Voltage		0.6		0.8	V
V _{IH(1)}	Input High Voltage	2.5V ≤ V _{CC} ≤ 5.5V	2.0		V _{CC} + 1	V
V _{OL1}	Output Low Voltage	I _{OL} = 2.1 mA			0.4	V
V _{OH1}	Output High Voltage	2.5V ≤ V _{CC} ≤ 5.5V	2.4			V
		I _{OH} = 0.4 mA				V

Note: 1. V_{IL} min and V_{IH} max are reference only and are not tested.

Table 3-4. Instruction Set for the AT93C46D

Instruction	SB	Op Code	Address		Data		Comments
			x 8	x 16	x 8	x 16	
READ	1	10	A ₆ - A ₀	A ₅ - A ₀			Reads data stored in memory, at specified address
EWEN	1	00	11XXXXX	11XXXX			Write enable must precede all programming modes
ERASE	1	11	A ₆ - A ₀	A ₅ - A ₀			Erase memory location A _n - A ₀
WRITE	1	01	A ₆ - A ₀	A ₅ - A ₀	D ₇ - D ₀	D ₁₅ - D ₀	Writes memory location A _n - A ₀
ERAL	1	00	10XXXXX	10XXXX			Erases all memory locations. Valid only at V _{cc} = 4.5V to 5.5V
WRAL	1	00	01XXXXX	01XXXX	D ₇ - D ₀	D ₁₅ - D ₀	Writes all memory locations. Valid only at V _{cc} = 4.5V to 5.5V
EWDS	1	00	00XXXXX	00XXXX			Disables all programming instructions



4. Functional Description

The AT93C46D is accessed via a simple and versatile 3-wire serial communication interface. Device operation is controlled by seven instructions issued by the host processor. A valid instruction starts with a rising edge of CS and consists of a Start Bit (logic “1”) followed by the appropriate Op Code and the desired memory Address location.

READ (READ): The Read (READ) instruction contains the address code for the memory location to be read. After the instruction and address are decoded, data from the selected memory location is available at the serial output pin DO. Output data changes are synchronized with the rising edges of serial clock SK. It should be noted that a dummy bit (logic “0”) precedes the 8- or 16-bit data output string.

ERASE/WRITE (EWEN): To assure data integrity, the part automatically goes into the Erase/Write Disable (EWDS) state when power is first applied. An Erase/Write Enable (EWEN) instruction must be executed first before any programming instructions can be carried out. Please note that once in the EWEN state, programming remains enabled until an EWDS instruction is executed or Vcc power is removed from the part.

ERASE (ERASE): The Erase (ERASE) instruction programs all bits in the specified memory location to the logical “1” state. The self-timed erase cycle starts once the ERASE instruction and address are decoded. The DO pin outputs the Ready/Busy status of the part if CS is brought high after being kept low for a minimum of 250 ns (t_{cs}). A logic “1” at pin DO indicates that the selected memory location has been erased, and the part is ready for another instruction.

WRITE (WRITE): The Write (WRITE) instruction contains the 8 or 16 bits of data to be written into the specified memory location. The self-timed programming cycle, t_{wp} starts after the last bit of data is received at serial data input pin DI. The DO pin outputs the Ready/Busy status of the part if CS is brought high after being kept low for a minimum of 250 ns (t_{cs}). A logic “0” at DO indicates that programming is still in progress. A logic “1” indicates that the memory location at the specified address has been written with the data pattern contained in the instruction and the part is ready for further instructions. A Ready/Busy status cannot be obtained if the CS is brought high after the end of the self-timed programming cycle, t_{wp} .

ERASE ALL (ERAL): The Erase All (ERAL) instruction programs every bit in the memory array to the logic “1” state and is primarily used for testing purposes. The DO pin outputs the Ready/Busy status of the part if CS is brought high after being kept low for a minimum of 250 ns (t_{cs}). The ERAL instruction is valid only at $V_{cc} = 5.0V \pm 10\%$.

WRITE ALL (WRAL): The Write All (WRAL) instruction programs all memory locations with the data patterns specified in the instruction. The DO pin outputs the Ready/Busy status of the part if CS is brought high after being kept low for a minimum of 250 ns (t_{cs}). The WRAL instruction is valid only at $V_{cc} = 5.0V \pm 10\%$.

ERASE/WRITE DISABLE (EWDS): To protect against accidental data disturb, the Erase/Write Disable (EWDS) instruction disables all programming modes and should be executed after all programming operations. The operation of the Read instruction is independent of both the EWEN and EWDS instructions and can be executed at any time.

5. Timing Diagrams

Figure 5-1. Synchronous Data Timing

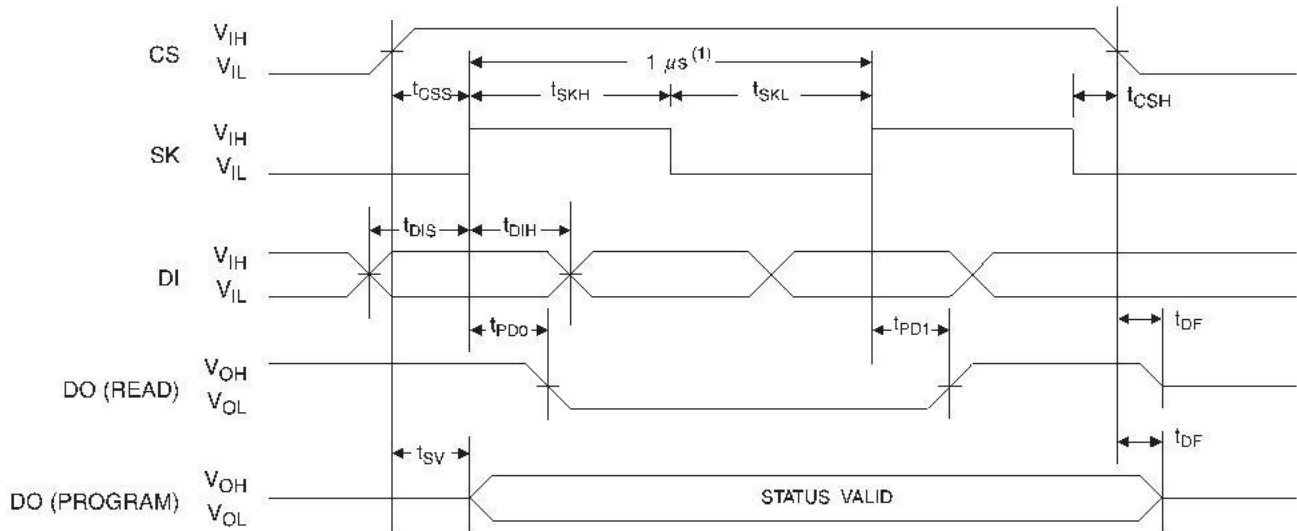

Note: 1. This is the minimum SK period.

Table 5-1. Organization Key for Timing Diagrams

I/O	AT93C46D (1K)	
	x 8	x 16
AN	A6	A5
DN	D7	D15

Figure 5-2. READ Timing

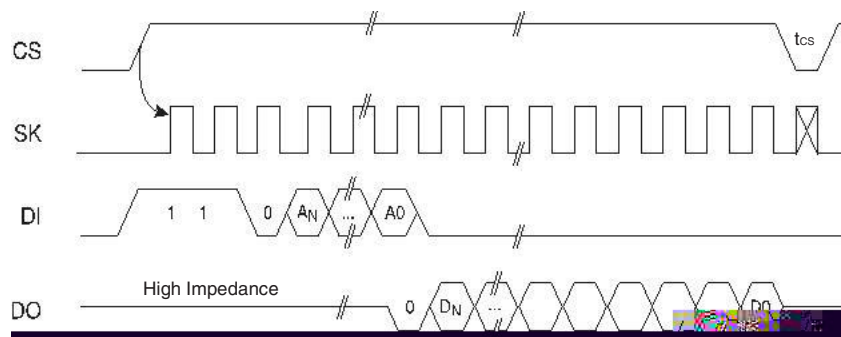

Figure 5-3. EWEN Timing

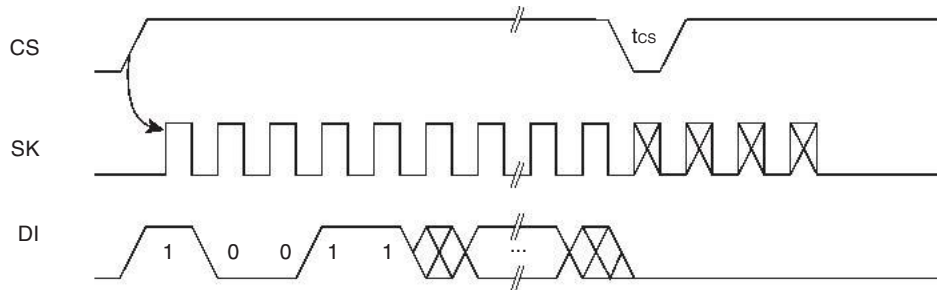

Figure 5-4. EWDS Timing

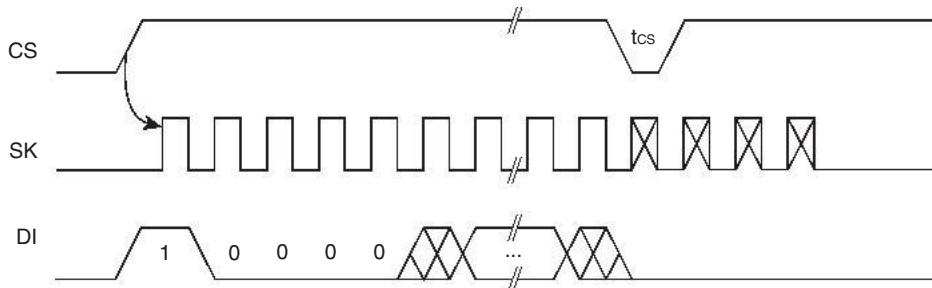

Figure 5-5. WRITE Timing

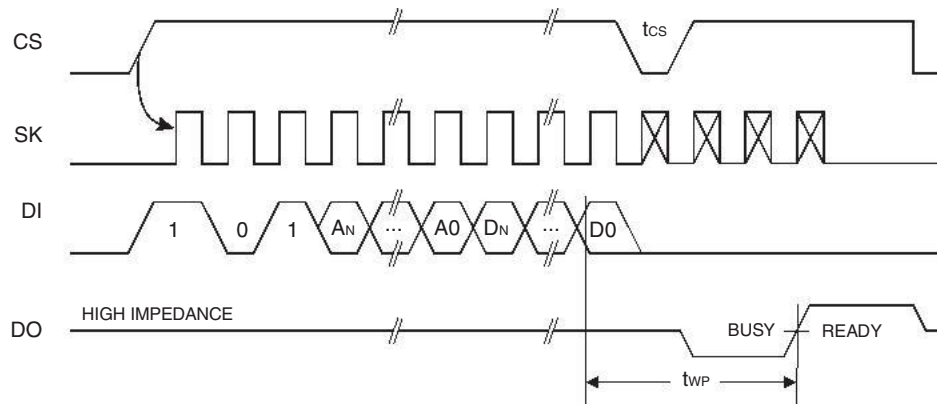
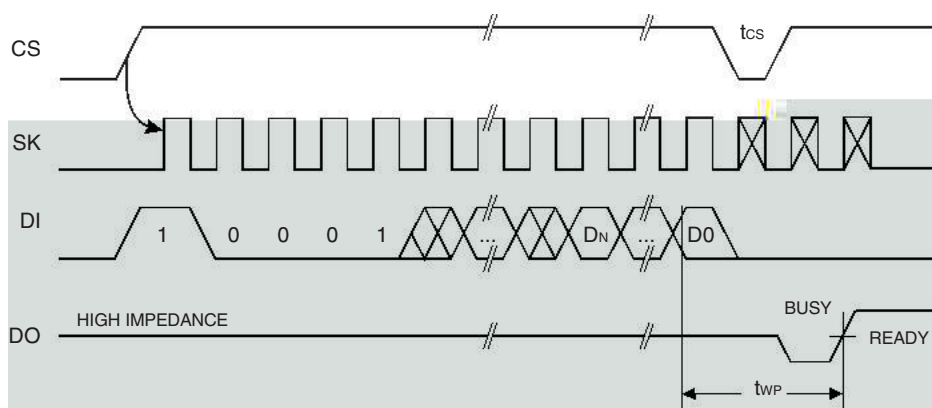

Figure 5-6. WRAL Timing⁽¹⁾



Note: 1. Valid only at $V_{cc} = 4.5V$ to $5.5V$.

Figure 5-7. ERASE Timing

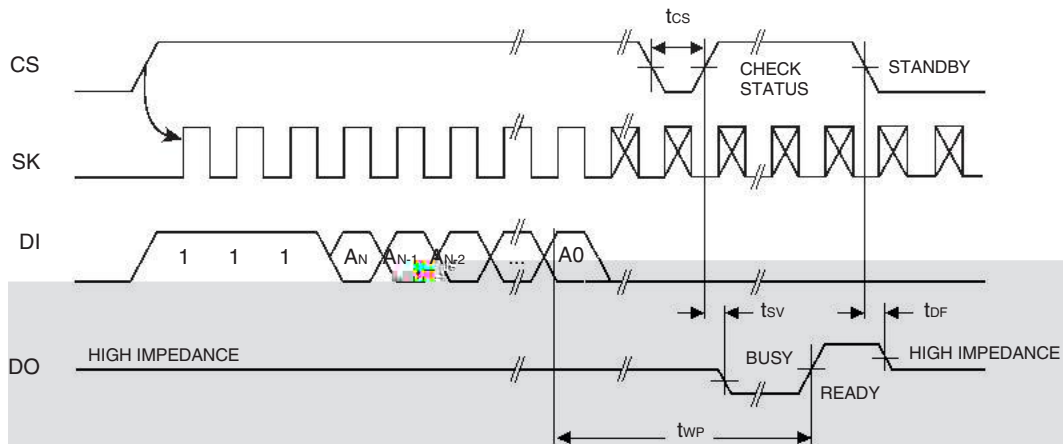
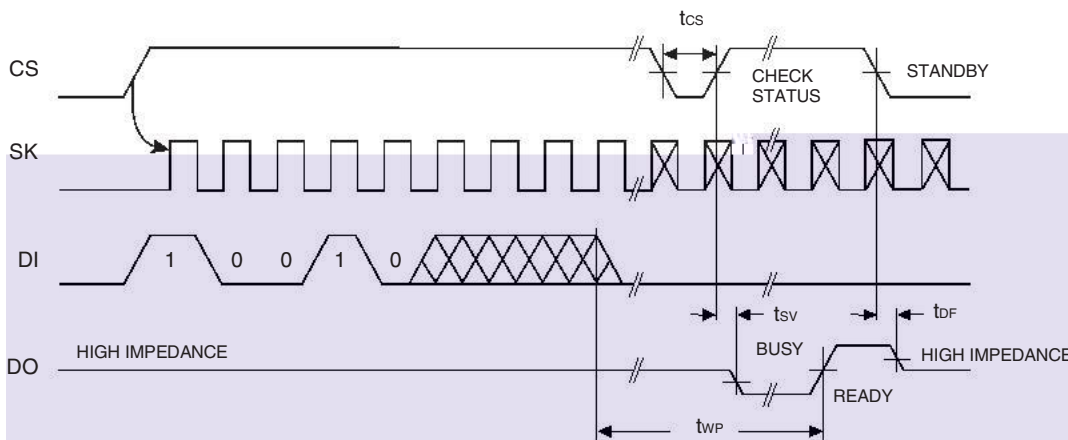

Figure 5-8. ERAL Timing⁽¹⁾



Note: 1. Valid only at Vcc = 4.5V to 5.5V.



6. AT93C46D Ordering Information

Ordering Code	Package	Operation Range
AT93C46DN-SP25-T ⁽¹⁾	8S1	Lead-Free/Halogen Free Automotive Temperature (-40 \oplus C to 125 \oplus C)
AT93C46DN-SP25-B ⁽³⁾	8S1	
AT93C46D-TP25-T ⁽²⁾	8A2	
AT93C46D-TP25-B ⁽³⁾	8A2	

- Notes:
1. T denotes Tape & Reel. 4K per reel.
 2. T denotes Tape & Reel. 5K per reel.
 3. B denotes Bulk.

Package Type	
8S1	8-lead, 0.150" Wide, Plastic Gull Wing Small Outline (JEDEC SOIC)
8A2	8-lead, 4.4 mm Body, Plastic Thin Shrink Small Outline Package (TSSOP)
Voltage Range	
Low Voltage (2.5V to 5.5V)	

Packaging Information

8S1 – JEDEC SOIC

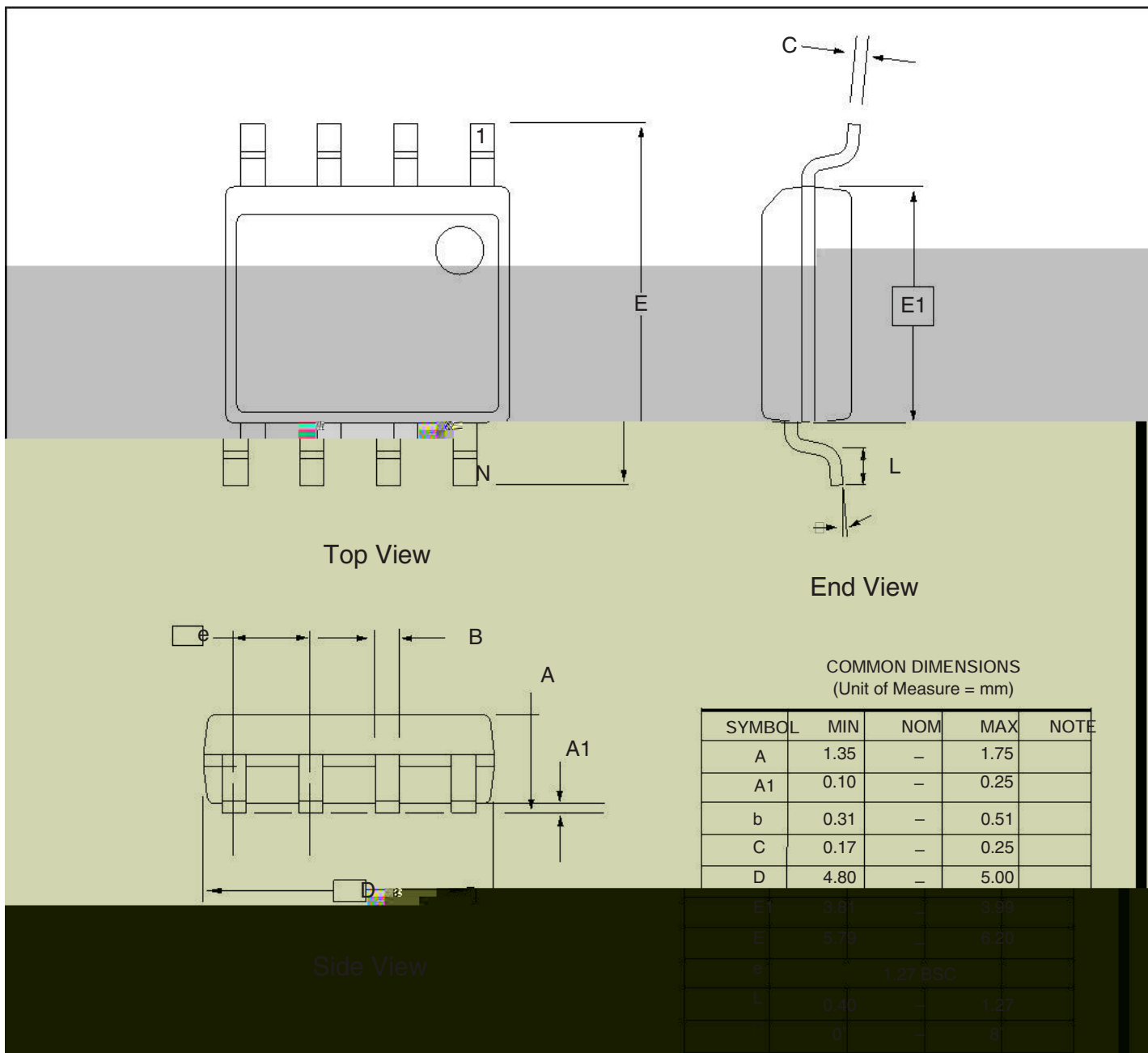

Note: These drawings are for general information only. Refer to JEDEC Drawing MS-012, Variation AA for proper dimensions, tolerances, datums, etc.

10/7/03

1150 E. Cheyenne Mtn. Blvd.
Colorado Springs, CO 80906

TITLE
8S1, 8-lead (0.150" Wide Body), Plastic Gull Wing
Small Outline (JEDEC SOIC)

DRAWING NO. REV
8S1 B

8A2 - TSSOP

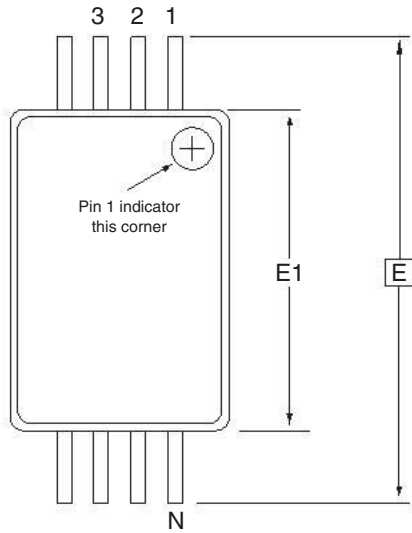

Top View

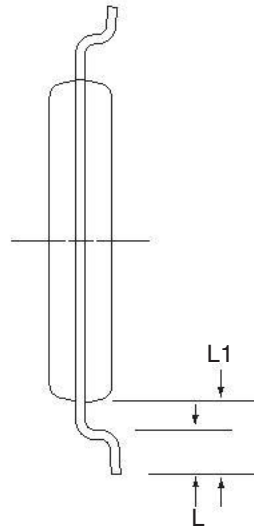

End View

COMMON DIMENSIONS
(Unit of Measure = mm)

SYMBOL	MIN	NOM	MAX	NOTE
D	2.90	3.00	3.10	2, 5
E	6.40 BSC			
E1	4.30	4.40	4.50	3, 5
A	-	-	1.20	
A2	0.80	1.00	1.05	
b	0.19	-	0.30	4
e	0.65 BSC			
L	0.45	0.60	0.75	
L1	1.00 REF			

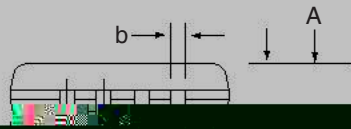

Side View

- Notes:
1. This drawing is for general information only. Refer to JEDEC Drawing MO-153, Variation AA, for proper dimensions, tolerances, datums, etc.
 2. Dimension D does not include mold Flash, protrusions or gate burrs. Mold Flash, protrusions and gate burrs shall not exceed 0.15 mm (0.006 in) per side.
 3. Dimension E1 does not include inter-lead Flash or protrusions. Inter-lead Flash and protrusions shall not exceed 0.25 mm (0.010 in) per side.
 4. Dimension b does not include Dambar protrusion. Allowable Dambar protrusion shall be 0.08 mm total in excess of the b dimension at maximum material condition. Dambar cannot be located on the lower radius of the foot. Minimum space between protrusion and adjacent lead is 0.07 mm.
 5. Dimension D and E1 to be determined at Datum Plane H.

5/30/02

2325 Orchard Parkway
San Jose, CA 95131

TITLE
8A2, 8-lead, 4.4 mm Body, Plastic
Thin Shrink Small Outline Package (TSSOP)

DRAWING NO. 8A2
REV. B

Revision History

Doc. Rev.	Date	Comments
8674A	4/2009	Initial document release.
		Updated Lit number and date Removed Preliminary Status

